

# Company Profile



# Carraro Technological Heritage in Agricultural Machinery: from Tractors to System Integrator

Founded in the 1930s as a manufacturing business focused on the production of sowing machines and equipment for agricultural works, over the years, the company has expanded and enjoyed increasing fame, becoming - as from midway through last century - one of Italy's most important tractor manufacturers.

From the 1970s onwards, Carraro concentrated its core business elsewhere, specialising in parts and becoming a key player in the world's manufacturers of drive systems for agricultural and earth-moving machinery.

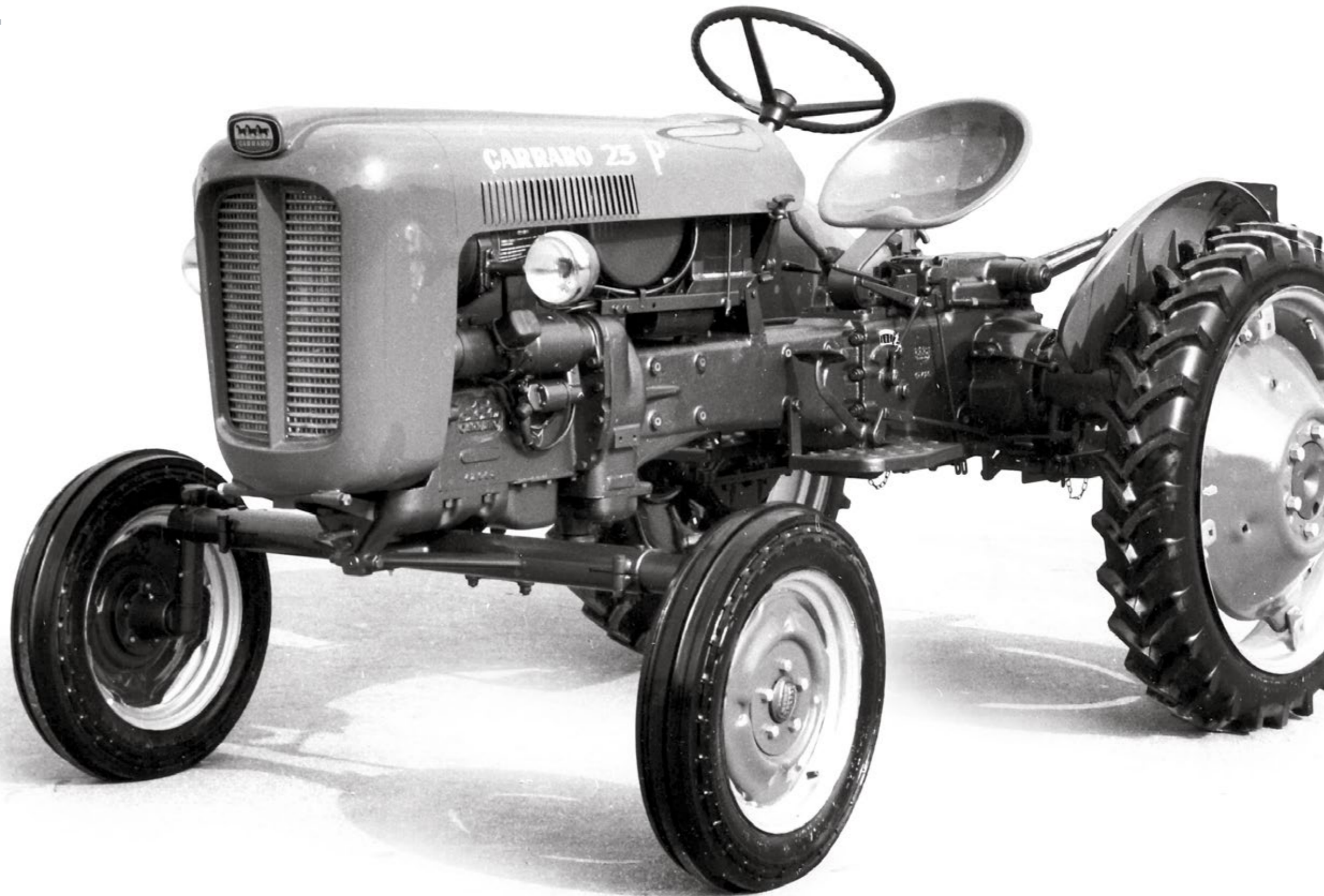





Carraro is a multinational Group and world leader in power transmission systems. Carraro core business consists in conceiving, designing, validating, manufacturing and marketing drive systems for construction equipment and agricultural machineries.





WAY TO EXIT  
↑

LIEBHERR LC 180

LIEBHERR LC 180

LIEBHERR LC 180

LIEBHERR 100A

Carraro systems have been designed for the optimal integration of mechanics and hydraulics, under the supervision of an advanced electronic control unit. This can best manage the whole driveline while monitoring and diagnosing the vehicle functions.



# Products



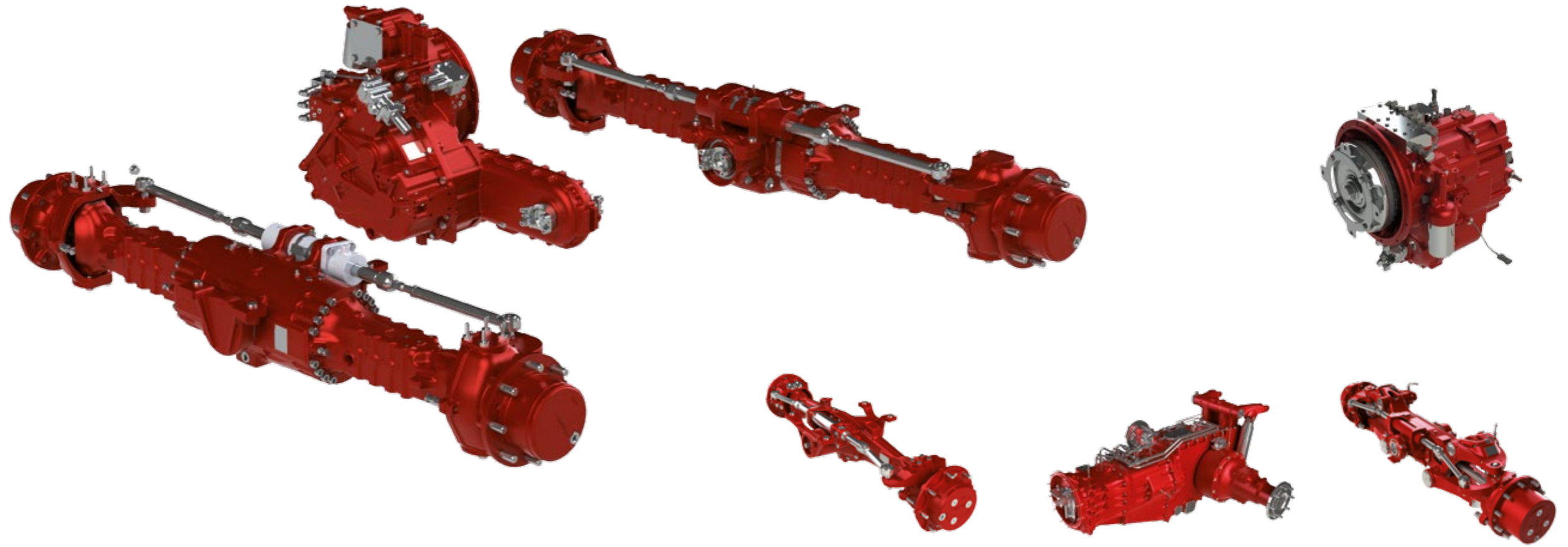

## Carraro Know-how as System Integrator Drivelines

Wherever there is a need for integrated transmission systems, Carraro has the solution, with a complete, diversified product range (axles and transmissions). Carraro drivelines have been optimised for the individual markets of application, to guarantee the very best efficiency and most practical vehicle layout.

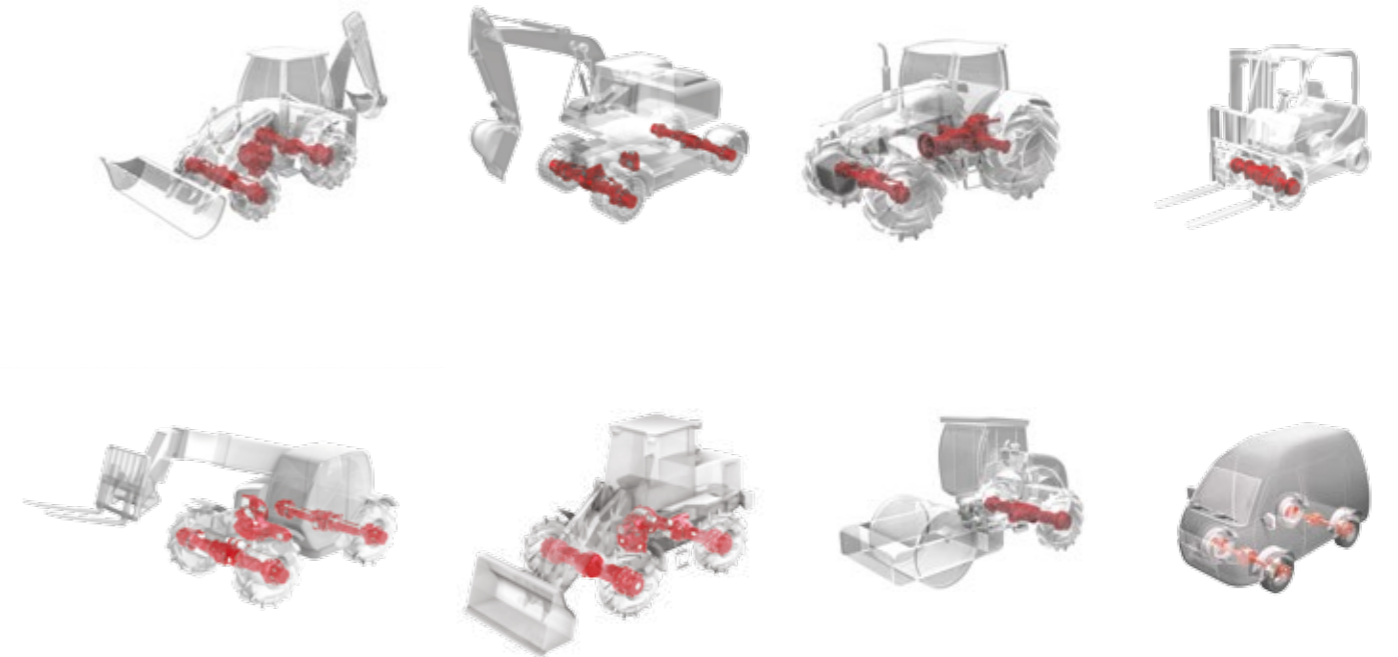



# Carraro Know-how as System Integrator Components

Carraro Group produces its own quality gears and components in-house to the very highest of standards.

In particular, operating through some of its production sites in Italy and India, today Carraro is able to produce cut steel gears for off-highway applications such as earth-moving machines, tractors, railway applications and trucks.

In order to serve these markets to the best of its ability, the component manufacturing plants are equipped with the most sophisticated steel cutting and processing technologies on the market. Thanks to this, today Carraro is a reference partner for all the main OEMs in all sectors and at international level.



## Carraro Know-how as System Integrator After Sales & Spare Parts

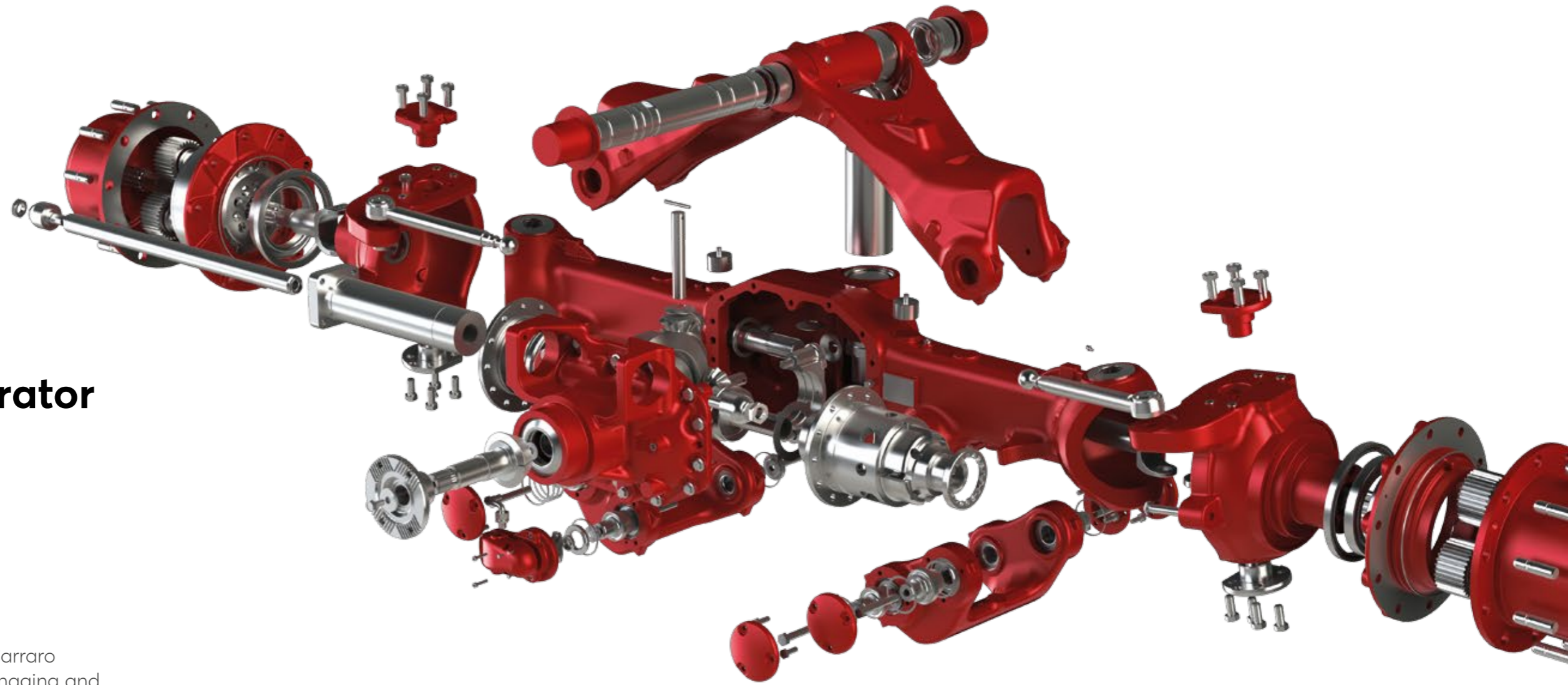

After Sales and Spare Parts is the Carraro Group's centre of excellence for managing and distributing original spare parts all over the world in order to guarantee total reliability for Carraro products:

- › More than 100 OEM's use our spare parts
- › Dedicated staff of 60 people in the world
- › 60.000 part numbers managed
- › Distributors and Service Centers in 90 Countries
- › Dedicated staff for technical support
- › Documentation, tools and solutions for maintenance and repair



# Our main customers

Ace  
Agco  
Agrale  
Agritech  
Alois Hieble  
Antonio Carraro  
Aslanlar  
Atm  
Basak  
Bozok  
Buhler  
Carraro Tractors  
Claas  
Cnh  
Daedong  
Dongfeng  
Erkunt  
Escorts  
Faresin  
Farmtrac Tractors  
Hars  
Hema  
Hirl  
Indo Farm  
Iran Tractor  
Jiangsu Changfa  
John Deere  
Kamol  
Kartar

Landini  
Lindner  
Liny Teak  
Ls Mtron  
Mahindra & Mahindra  
Ostmco  
Pauny  
Preet Tractors  
Reformwerke  
Same Deutz  
Sauerburger  
Shandong Juming  
Shandong Lovol  
Shandong Wuzheng  
Sitrex  
Sonalika  
Strautmann  
Tafe  
Tatoma  
Tong Yang  
Trioliet  
Tumosan  
Ursus  
Xgma  
Xuzhou Kat  
Yto  
Zetor  
Zoomlion



The "Local for Local" philosophy has not been adopted by Carraro just to realize its Global Manufacturing Footprint, but also in the product development approach.

Thanks to the local engineering presence, Carraro has achieved a deep knowledge of customer needs not only in the traditionally markets, but also of the emerging ones.

The Group has always been committed to developing power transmission systems with a focus on greater efficiency and ecological sustainability.

Today, these requisites are fundamental for tackling an increasingly competitive market.



# Local for Local Approach

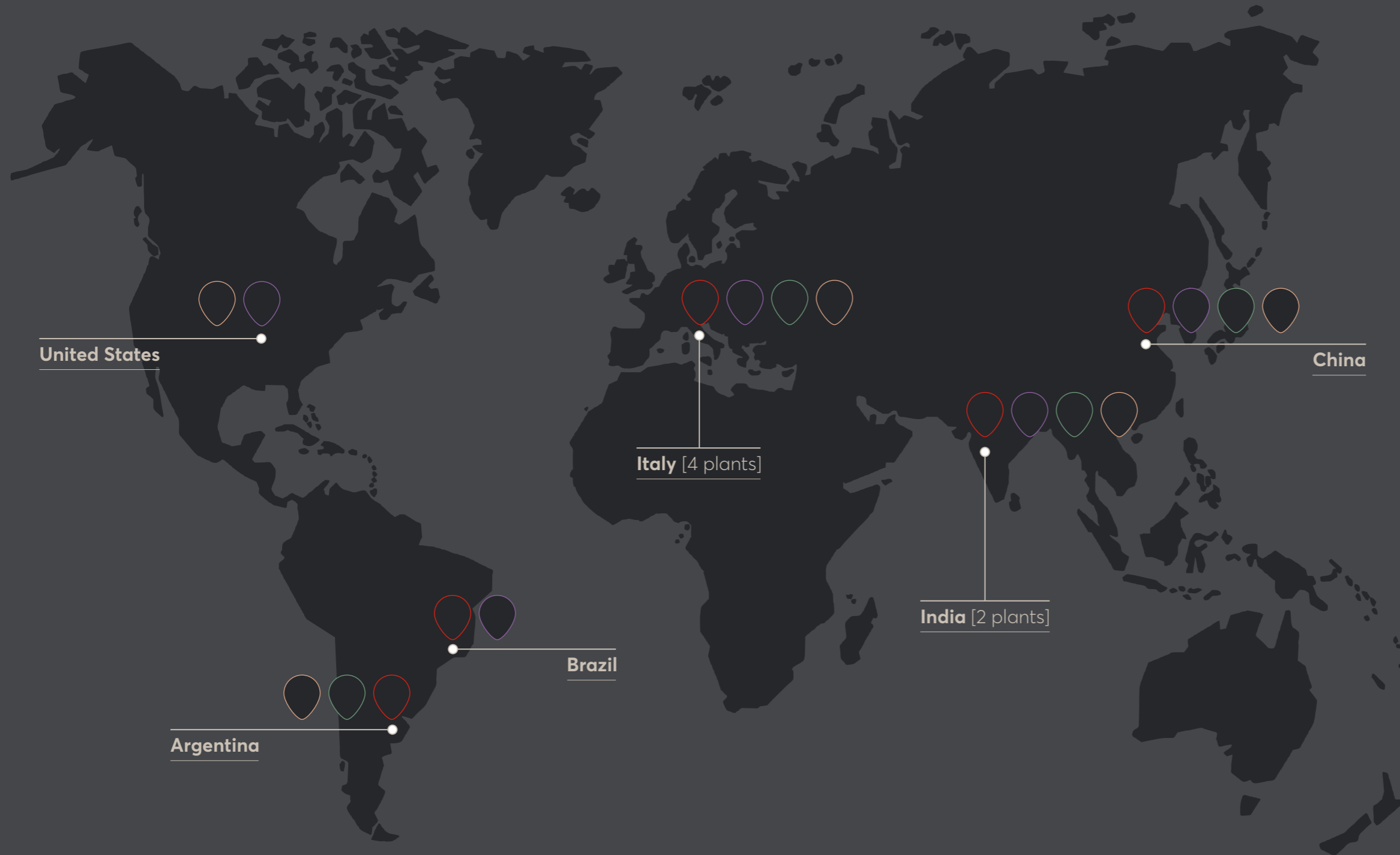

Plants	Branches
Italy	Italy
Argentina	USA
Brazil	Brazil
China	China
India	India
	Argentina

Engineering Centres	Spare Parts Centres
Italy	Italy
Argentina	USA
China	Argentina
India	China
	India



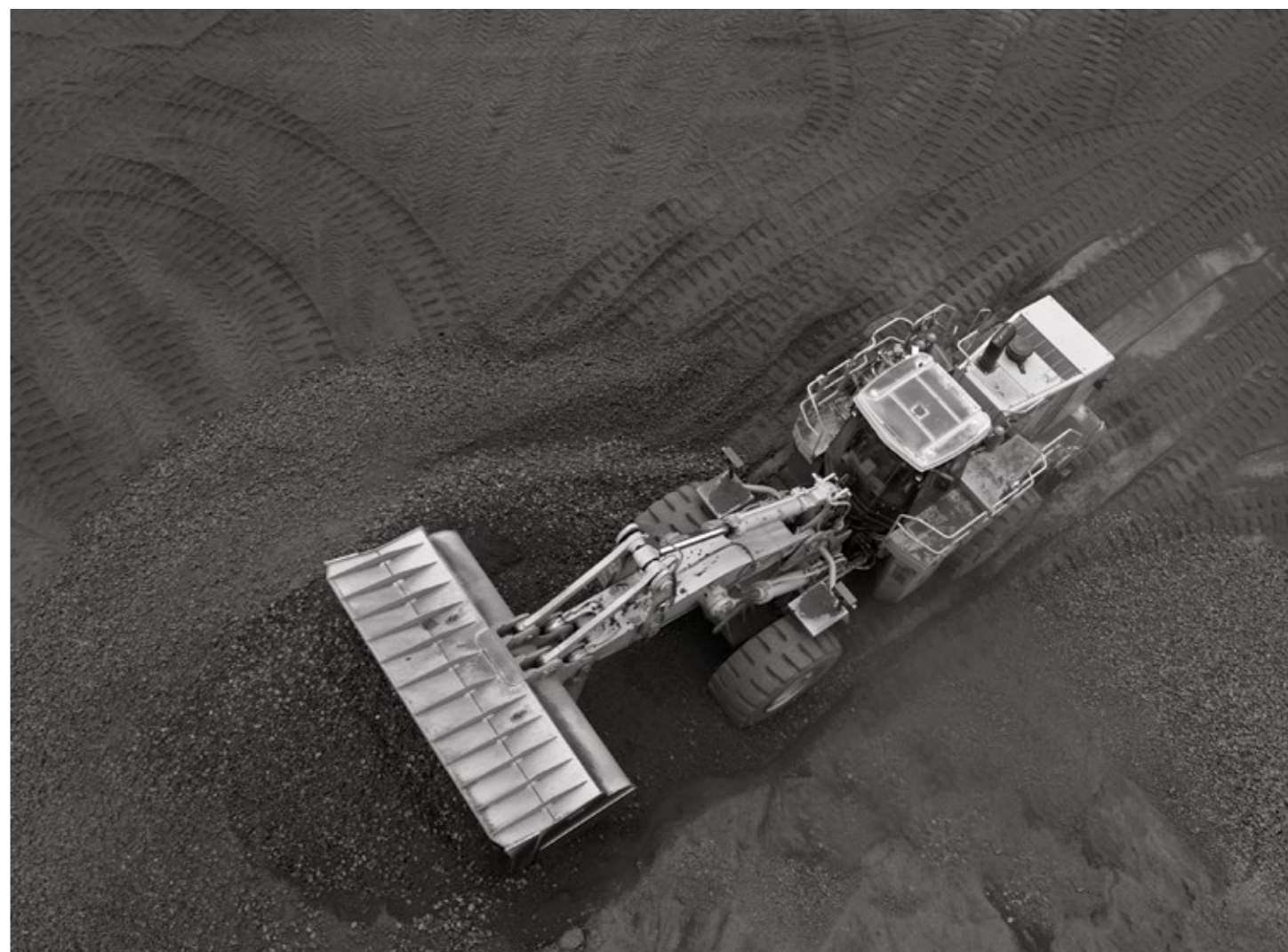



A close-up photograph of a red tractor component, likely a wheel hub or suspension part, showing the metallic texture and the bright red paint. The lighting creates strong highlights and shadows, emphasizing the industrial design.

**We Know  
How To Do It.  
From Tractors  
to Components.**

**carraro.com**

**Carraro Spa  
Headquarters**

Via Olmo, 37  
35011 Campodarsego  
(Padova), Italy  
T +39 049 9219111  
F +39 049 9289111  
[webinfo@carraro.com](mailto:webinfo@carraro.com)